

We understand water.

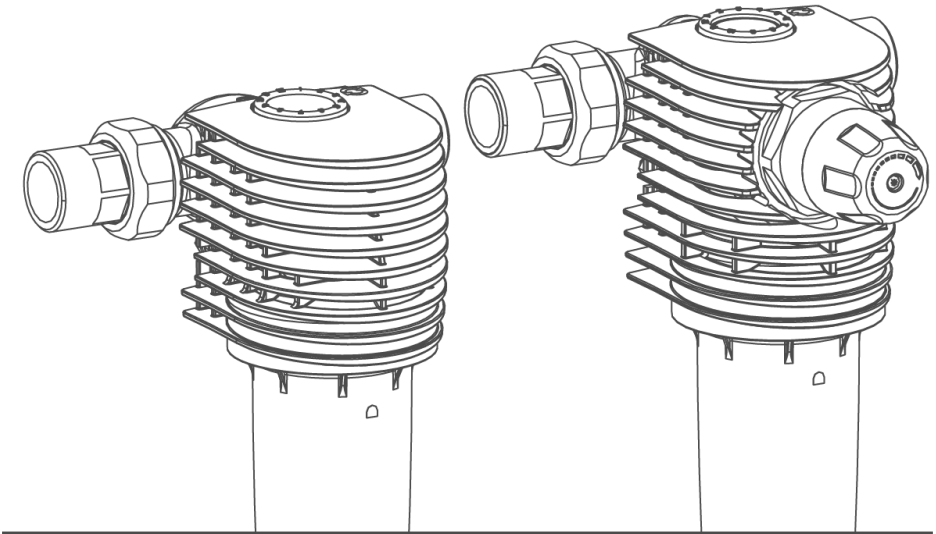

Fine filter | BOXER KX/KDX $\frac{3}{4}$ ", 1", 1 $\frac{1}{4}$ "

Operation manual

grünbeck

General Contact
Germany

International Sales

 +49 9074 41-145

Service

 +49 9074 41-333
service@gruenbeck.de

Availability

Monday to Thursday
7:00 am - 6:00 pm

Friday
7:00 am - 4:00 pm

We reserve the right to technical modifications.
© by Grünbeck AG

Original operation manual
Edition: February 2025
Order no.: TD3-AK001_en_055

Table of contents

1	Introduction	5	6.1	Checking the product.....	24
1.1	Validity of the manual	5	6.2	Setting the month indicator	25
1.2	Product identification	6	6.3	Setting the pressure reducer (BOXER KDX)	26
1.3	Symbols used	7	6.4	Handing over the product to the owner/operating company	27
1.4	Depiction of warnings	7			
1.5	Demands on personnel.....	8			
2	Safety	11	7	Operation	28
2.1	Safety measures	11	7.1	Installing Grünbeck's myProduct app.....	28
2.2	Product-specific safety instructions.....	12			
2.3	Conduct in emergencies	12	8	Maintenance and repair	29
3	Product description	13	8.1	Cleaning	29
3.1	Intended use	13	8.2	Intervals	30
3.2	Product components	14	8.3	Inspection	31
3.3	Functional description	15	8.4	Maintenance	32
3.4	Accessories	15	8.5	Consumables.....	37
4	Transport and storage	16	8.6	Spare parts	37
4.1	Transport	16	8.7	Wearing parts	37
4.2	Storage	16	9	Troubleshooting	39
5	Installation	17	9.1	Observations	39
5.1	Requirements for the installation site	19	10	Decommissioning	41
5.2	Checking the scope of supply.....	20	10.1	Temporary downtime	41
5.3	Water installation	21	11	Dismantling and disposal	42
6	Start-up/Commissioning	24	11.1	Dismantling	42
			11.2	Disposal	43
			12	Technical specifications	44

12.1	BOXER KX.....	44
12.2	Pressure loss curves BOXER KX ..	45
12.3	BOXER KDX	46

13 Operation log..... 48

13.1	Start-up/Commissioning log.....	48
13.2	Maintenance	49

1 Introduction

This manual is intended for owners/operating companies, operators/users as well as qualified specialists and ensures the safe and efficient handling of the product. The manual is an integral part of the product.

- Carefully read this manual and the included manuals on the components before you operate your product.
- Obey all safety and handling instructions.
- Keep this manual and all other applicable documents, so that they are available when needed.

Illustrations in this manual are for basic understanding and can differ from the actual design.

1.1 Validity of the manual

This manual applies to the products below:

- Fine filter BOXER KX/KDX $\frac{3}{4}$ " (DN 20)
- Fine filter BOXER KX/KDX 1" (DN 25)
- Fine filter BOXER KX/KDX $1\frac{1}{4}$ " (DN 32)

1.2 Product identification

You can identify your product based on the product designation and the order no. indicated on the type plate.

- ▶ Check whether the products indicated in chapter 1.1 correspond to your product.







The type plate is located on the filter head.



Designation	
1	Nominal connection diameter
2	Flow rate
3	Nominal pressure
4	Water temperature
5	Pore size
6	DVGW test mark

Designation	
7	Obey the operation manual
8	Data matrix code
9	Serial no.
10	Order no.
11	QR code
12	Product designation

1.3 Symbols used

Symbol	Meaning
	Danger and risk
	Important information or requirement
	Useful information or tip
	Written documentation required
	Reference to further documents
	Work that must be carried out by qualified specialists only
	Work that must be carried out by technical service personnel only

1.4 Depiction of warnings



This manual contains information and instructions that you must obey for your personal safety. The information and instructions are highlighted by a warning symbol and are structured as shown below:



SIGNAL WORD Type and source of hazard

- Possible consequences
- ▶ Preventive measures

The signal words below are defined subject to the degree of danger and might be used in the present document:

Warning symbol and signal word	Consequences if the information/instructions are ignored	
 DANGER		Death or serious injuries
 WARNING	Personal injury	Possible death or serious injuries
 CAUTION		Possible moderate or minor injuries
NOTE	Damage to property	Possible damage to components, the product and/or its functions, or an object in its vicinity

1.5 Demands on personnel

During the individual life cycle phases of the product, different people carry out work on the product. This work requires different qualifications.

1.5.1 Qualification of personnel

Personnel	Requirements
Operator/user	<ul style="list-style-type: none"> • No special expertise required • Knowledge of the tasks assigned • Knowledge of possible dangers in case of incorrect behaviour • Knowledge of the required protective equipment and protective measures • Knowledge of residual risks
Owner/ operating company	<ul style="list-style-type: none"> • Product-specific expertise • Knowledge of statutory regulations on work safety and accident prevention

Personnel	Requirements
Qualified specialist <ul style="list-style-type: none"> • Electrical engineering • Sanitary engineering (HVAC and plumbing) • Transport 	<ul style="list-style-type: none"> • Professional training • Knowledge of relevant standards and regulations • Knowledge of detection and prevention of potential hazards • Knowledge of statutory regulations on accident prevention
Technical service (Grünbeck's technical service/authorised service company)	<ul style="list-style-type: none"> • Extended product-specific expertise • Trained by Grünbeck

1.5.2 Authorisations of personnel

The table below describes which tasks may be carried out by whom.

	Operator/ user	Owner/ operating company	Qualified specialist	Technical service
Transport and storage		X	X	X
Installation and mounting			X	X
Start-up/Commissioning			X	X
Operation and handling	X	X	X	X
Cleaning	X	X	X	X
Inspection	X	X	X	X
Maintenance	semi-annually	X	X	X
	annually		X	X
Troubleshooting		X	X	X
Repair			X	X
Decommissioning and restart/recommissioning			X	X
Dismantling and disposal			X	X

1.5.3 Personal protective equipment

You do not need any protective equipment to operate the product.

- ▶ Recommendation: Use hygienic gloves when replacing the filter element and cleaning the support mesh in order to prevent bacterial growth.



Protective gloves

2 Safety

2.1 Safety measures

- Only operate your product if all components are installed properly.
- Obey the local regulations on drinking water protection, accident prevention and occupational safety.
- Do not make any changes, alterations or extensions on your product. Only use genuine spare parts for maintenance or repair.
- Keep the premises locked against unauthorised access to protect imperilled or untrained persons from residual risks.
- Comply with the maintenance intervals (refer to chapter 8.2). Failure to comply can result in the microbiological contamination of your drinking water system.

2.1.1 Pressure-related hazards

- Components can be under pressure. There is a risk of injuries and damage to property due to escaping water and unexpected movement of components. Check the pressure lines and the product for leaks at regular intervals.
- Before starting repair and maintenance work, make sure that all affected components are depressurised.

2.1.2 Groups of persons requiring protection

- Children must not play with the product.
- This product is not designed to be used by persons (including children) with reduced capabilities, lack of experience or lack of knowledge. Unless they are supervised, have been instructed on the safe use of the product and understand the resulting hazards.
- Cleaning and maintenance must not be carried out by children.

2.2 Product-specific safety instructions



WARNING

Excessive contamination of the filter element

- Health risk due to contamination of the drinking water
- ▶ Comply with the intervals for inspection and replacement of the filter element (according to DIN EN 806-5 every 6 months at the latest).

2.3 Conduct in emergencies

2.3.1 In case of water leaks

1. Close the shut-off valves for the water flow upstream and downstream of the filter.
2. Locate the leak.
3. Eliminate the cause of the water leak.

3 Product description

3.1 Intended use

- The fine filters BOXER KX and BOXER KDX are designed for filtering drinking water.
- The fine filter BOXER KDX with pressure reducer in addition is suitable for the adjustment of the outlet pressure on the withdrawal side in order to maintain the max. admissible operating pressure stipulated in DIN EN 806-2. The adjustment of the outlet pressure on the withdrawal side, however, only works when applied in the positive pressure range.
- The filters can be used for positive and negative pressure applications.
- The filters are designed according to the stipulations of DIN EN 13443-1 and DIN 19628 and are intended for installation into drinking water pipes according to DIN EN 806-2 (installation immediately downstream of the water meter).
- They protect the water pipes and connected water-carrying system parts from disturbances and corrosion damage due to undissolved impurities (particles) such as rust particles, sand, etc.

3.1.1 Foreseeable misuse

- The filters are not suitable for circulation water that has been treated with chemicals.
- The filters are neither suitable for oils, greases, solvents, soaps and other lubricating media, nor for the separation of water-soluble substances.

3.2 Product components

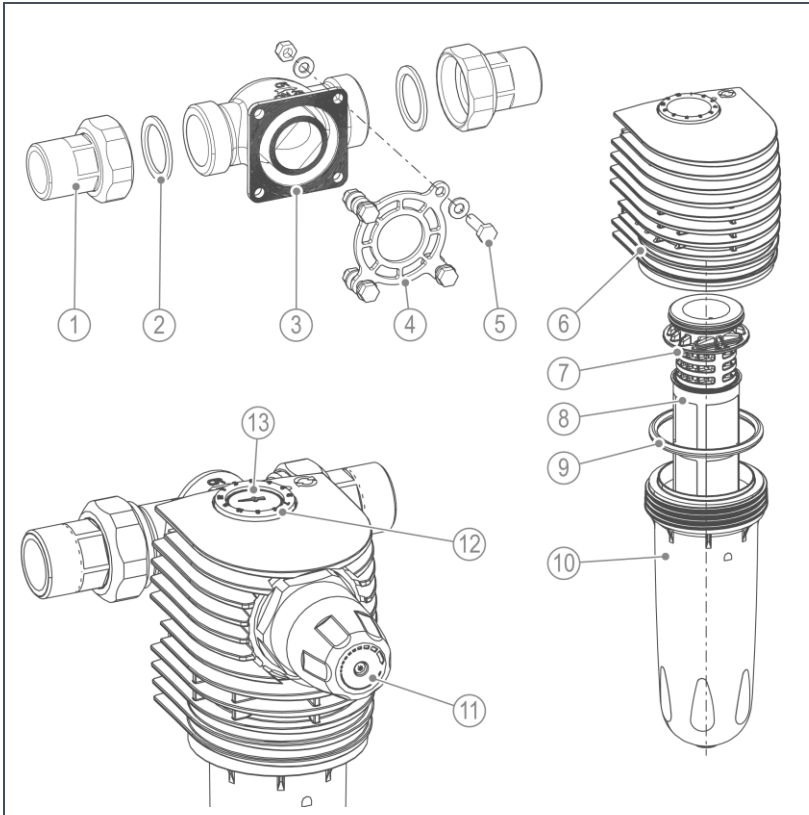

Designation

- | | |
|---|------------------------------|
| 1 | Water meter screw connection |
| 2 | Seal |
| 3 | Connection flange |
| 4 | Flange seal |
| 5 | Screw connection kit |
| 6 | Filter head |
| 7 | Support mesh |

Designation

- | | |
|----|----------------------------|
| 8 | Filter element |
| 9 | O-ring of filter cylinder |
| 10 | Filter cylinder |
| 11 | Pressure reducer cartridge |
| 12 | Maintenance ring |
| 13 | Pressure gauge |

3.3 Functional description

The unfiltered drinking water flows into the filter through the inlet side and from the outside in through the filter element and to the pure water outlet. Thus, foreign particles of a size > 100 µm are retained.

Depending on their size and weight, the foreign particles either stick to the filter element, or they fall straight down into the filter cylinder.

In the fine filter BOXER KDX, the flow-optimised pressure reducer, which is designed according to DIN EN 1567, additionally enables the outlet pressure on the withdrawal side to be set to 1 – 6 bar (factory setting: 4 bar).

3.4 Accessories

You can retrofit your product with accessories. Please contact your local Grünbeck representative or Grünbeck’s headquarters in Hochstaedt/Germany for details.

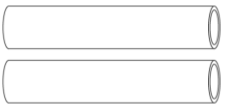
Illustration	Product	Order no.
	50 µm filter element (2 pieces)	103 068
	20 µm filter element (2 pieces)	103 071
	5 µm filter element (2 pieces)	103 081
As per DIN EN 13433-1, filter elements of 5 µm, 20 µm and 50 µm are not admissible for drinking water installations.		

4 Transport and storage

4.1 Transport

- ▶ Transport the product in its original packaging only.

4.2 Storage

- ▶ Protect the product from the impacts below when storing it:
 - Dampness, moisture
 - Environmental impacts such as wind, rain, snow, etc.
 - Frost, direct sunlight, severe heat exposure
 - Chemicals, dyes, solvents and their vapours

5 Installation



The installation of the product represents a major intervention into the drinking water system and must be carried out by a qualified specialist only.

In accordance with DIN EN 806-2 and DIN EN 1717, the product is installed in the cold water pipe downstream of the water meter and upstream of distribution pipes and the appliances to be protected.

Installation example in horizontal pipe

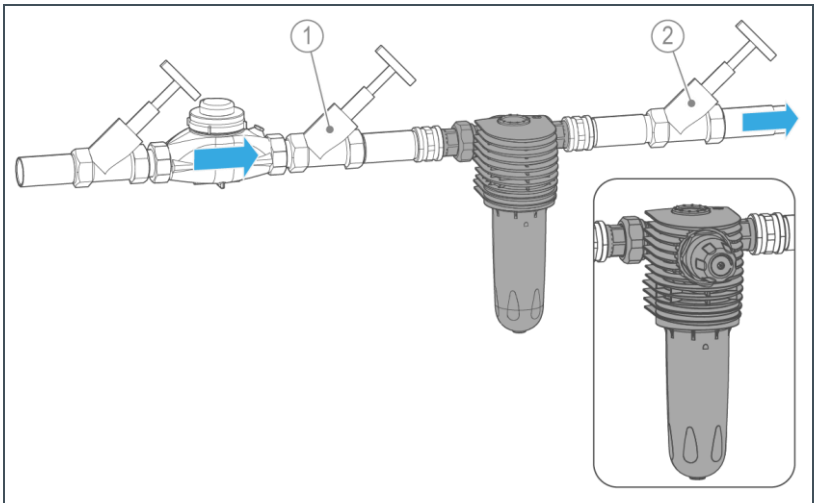

Designation

1 Inlet shut-off valve

Designation

2 Outlet shut-off valve

Installation example in vertical pipe

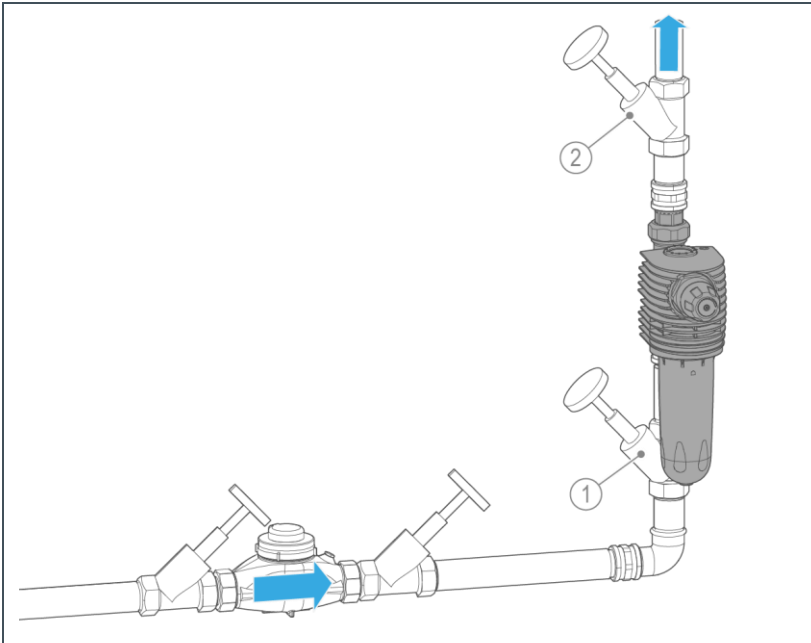

Designation

1 Inlet shut-off valve

Designation

2 Outlet shut-off valve

5.1 Requirements for the installation site

- The installation site must be frost-proof and ensure the filter's protection from chemicals, dyes, solvents and their vapours as well as from direct sunlight.
- The installation site must be away from heat sources (e.g. washing machines, boilers and hot water pipes).
- The installation room must provide a floor drain. If no floor drain is available, an appropriate safety device must be installed in order to prevent water damage.
- The installation site must be adequately illuminated and ventilated.
- The installation site must be easily accessible for maintenance purposes.

5.2 Checking the scope of supply

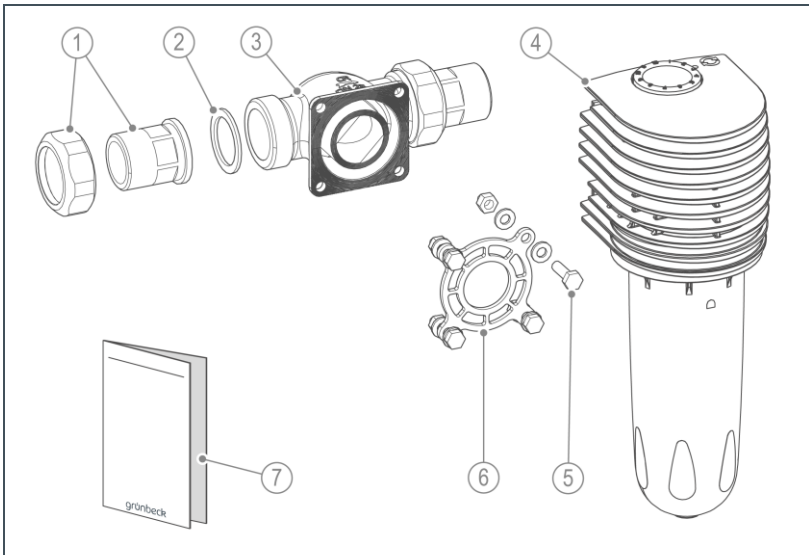

Designation	
1	Water meter screw connection
2	Seal
3	Connection flange
4	Fine filter BOXER KX or BOXER KDX

Designation	
5	Screw connection kit
6	Flange seal
7	Quick reference manual

- ▶ Check the scope of supply for completeness and damage.

5.3 Water installation



The filter can be installed in a horizontal or vertical water pipe.

5.3.1 Preparing the pipe

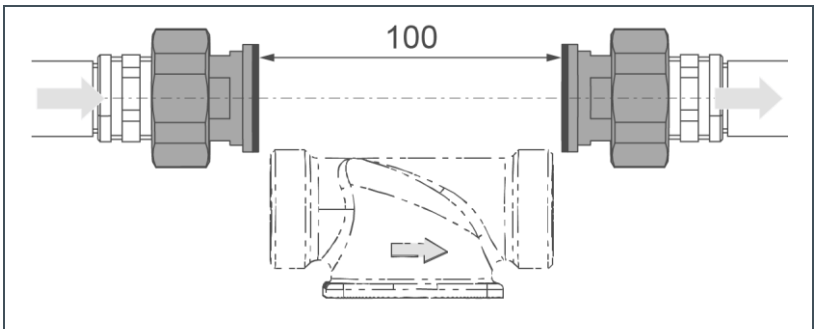

- ▶ Install the water meter screw connection in the pipe.
- » The distance between the two seals must be 100 mm.

5.3.2 Installing the connection flange

- ▶ Check the flow direction given on site.

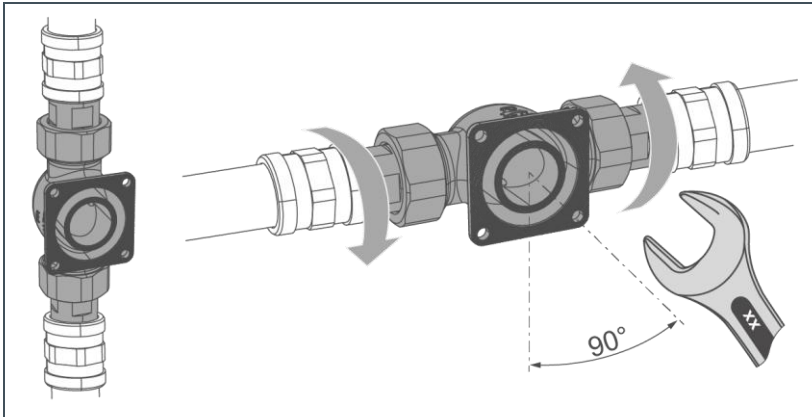

1. Rotate the connection flange into the position matching your flow direction (refer to the marking on the connection flange).
 - » The arrow must correspond to the flow direction of the water.
2. Tighten the connection flange with the union nuts without applying any mechanical stress.

5.3.3 Mounting the filter



Do not grease the flange seal. Greased flange seals can cause leaks and malfunctions.

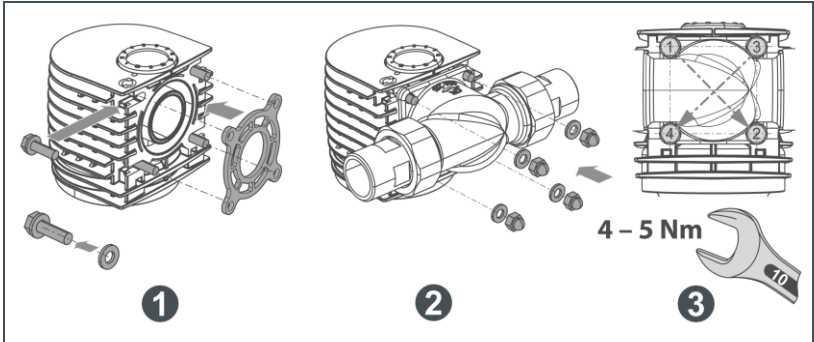

1. Insert the hexagonal screws with washers into the recesses on the filter head.
2. Slide on the flange seal.
3. Screw the filter onto the connection flange. Tighten the 4 nuts crosswise with 4 – 5 Nm. .

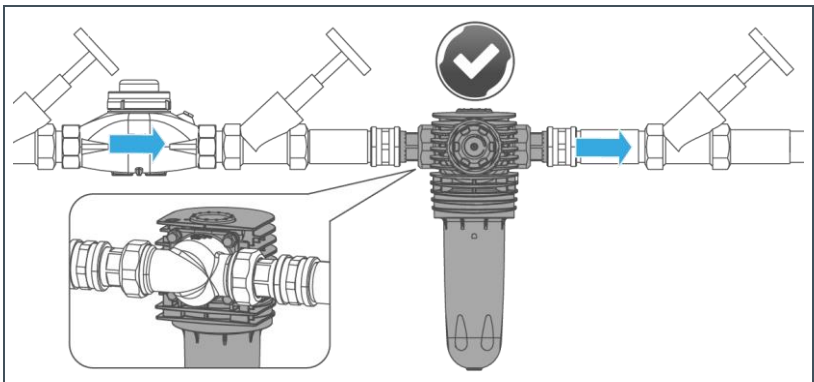

» The filter is installed.

6 Start-up/Commissioning



The initial start-up/commissioning of the product must be carried out by technical service personnel only.

6.1 Checking the product

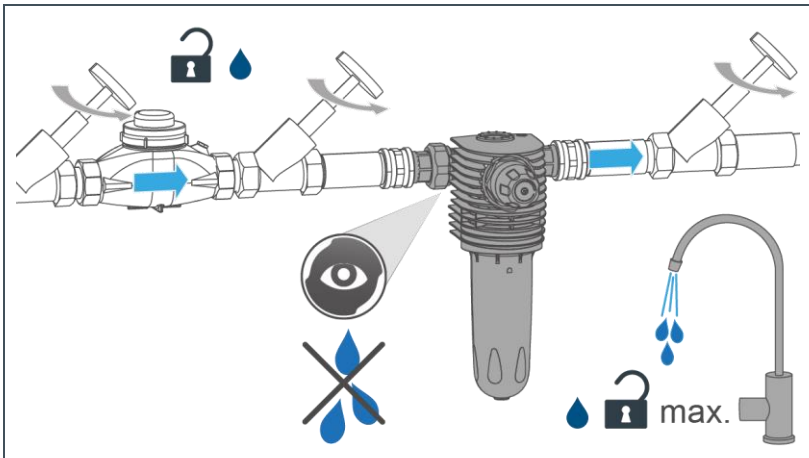

1. Open the shut-off valves.
2. Open the closest water withdrawal point downstream of the filter to the maximum.
 - » The filter is vented.
3. Check the filter for leaks.
4. Enter the initial start-up/commissioning in the operation log (refer to chapter 13).
 - » The filter is in operation.

6.2 Setting the month indicator



Via Grünbeck's myProduct app, you will receive a message about the timely replacement of the filter element (refer to chapter 7.1).

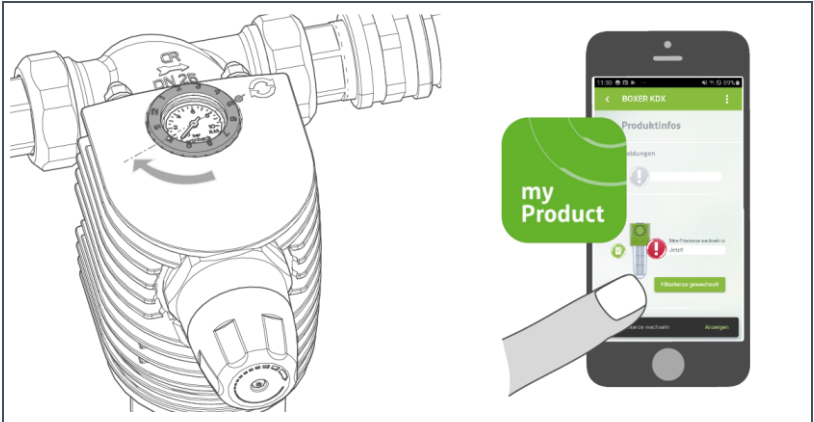

- ▶ Set the maintenance ring to the month of the next maintenance (alternatively, to the month of the next replacement of the filter element – every six months at the latest).

6.3 Setting the pressure reducer (BOXER KDX)

The factory setting for the pressure reducer is 4 bar.

You can change this value as follows:

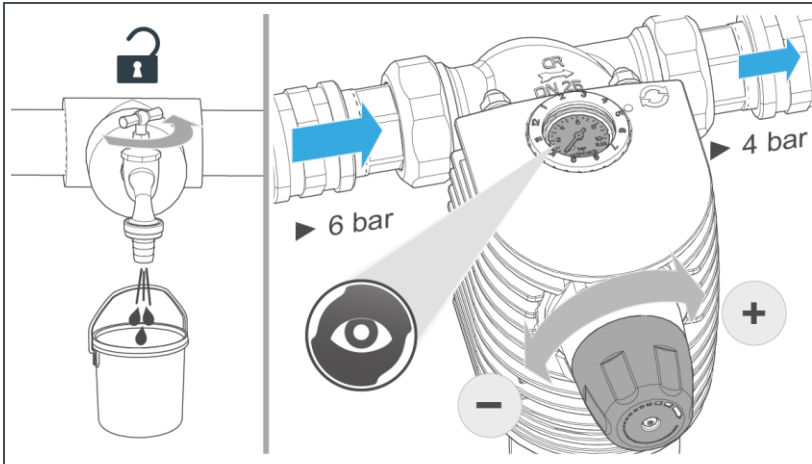

1. Set the required outlet pressure on the pressure reducer handwheel (turn clockwise = pressure increase, turn counter-clockwise = pressure reduction).
2. Open and close a water withdrawal point.
 - » The outlet pressure adjusts itself.
3. Read the actual outlet pressure on the pressure gauge.
4. Repeat steps 1. – 3. until the desired pressure is reached.
 - » The desired outlet pressure is set.



The outlet pressure is set according to DIN EN 806-2.

- ▶ Comply with the max. admissible operating pressure.

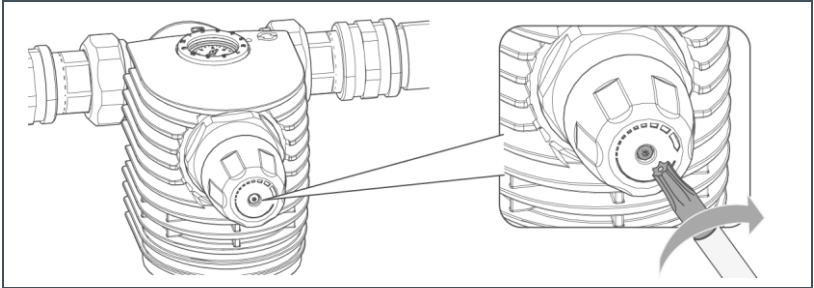

The screw of the pressure reducer cartridge can come loose.

- ▶ Tighten the screw during annual maintenance (refer to chapter 8.4.2) and whenever required.

6.4 Handing over the product to the owner/ operating company

- ▶ Explain to the owner/operating company how the product works.
- ▶ Use the manual to brief the owner/operating company and answer any questions.
- ▶ Inform the owner/operating company about the need for inspections and maintenance.
- ▶ Hand over all documents to the owner/operating company for keeping.

6.4.1 Disposal of packaging

- ▶ Dispose of packaging material as soon as it is no longer needed (refer to chapter 11.2).

7 Operation

The filter is operated automatically and does not require any manual operation.

- ▶ Inspect the filter at regular intervals (refer to chapter 8.3).
- ▶ Replace the filter element at regular intervals (refer to chapter 8.4.1).
- ▶ Flush the filter after a temporary downtime (refer to chapter 10.1).

7.1 Installing Grünbeck's myProduct app



You can register your product using Grünbeck's my-Product app.

That way, you will receive a reminder to replace the filter element as well as additional information on your product

- ▶ Download Grünbeck's myProduct app and install it on your mobile device.

8 Maintenance and repair

Maintenance and repair includes cleaning, inspection and maintenance of the product.



The responsibility for inspection and maintenance is subject to local and national requirements. The owner/operating company is responsible for compliance with the prescribed maintenance and repair work.



By concluding a maintenance contract you make sure that all maintenance work will be carried out on time.

- ▶ Only use genuine spare and wearing parts from Grünbeck.

8.1 Cleaning

NOTE

Do not clean the product with cleaning agents containing alcohol/solvents

- These substances damage the plastic components
- ▶ Use a mild/pH-neutral soap solution.
- ▶ Only clean the outside of the product.
- ▶ Do not use any strong or abrasive cleaning agents.
- ▶ Wipe the surfaces with a damp cloth.

8.2 Intervals



By way of regular inspections and maintenance, malfunctions can be detected in time and product failures might be prevented.

- ▶ As owner/operating company determine which components must be inspected and maintained at which intervals (load-dependent). This is subject to the actual conditions such as: water condition, degree of impurities, environmental impacts, consumption, etc.

The interval table below shows the minimum intervals for the activities to be carried out.

Task	Interval	Activities
Inspection	2 months	<ul style="list-style-type: none"> • Visual/functional check • Read the pressure (for BOXER KDX)
Maintenance	6 months	<ul style="list-style-type: none"> • Replace the filter element • Clean the support mesh (if needed) • Condition and leak check • Set the maintenance ring
	annually as needed	<ul style="list-style-type: none"> • Replace the filter element • Check O-rings/flat seals for wear and tear • Check for tight fit
Repair	5 years	<ul style="list-style-type: none"> • Recommendation: Replace support mesh and seals
	10 years	<ul style="list-style-type: none"> • Recommendation: Replace the filter cylinder

8.3 Inspection

You as owner/operating company can carry out the regular inspections yourself.

- ▶ Carry out an inspection at least every 2 months and proceed as follows to do so:

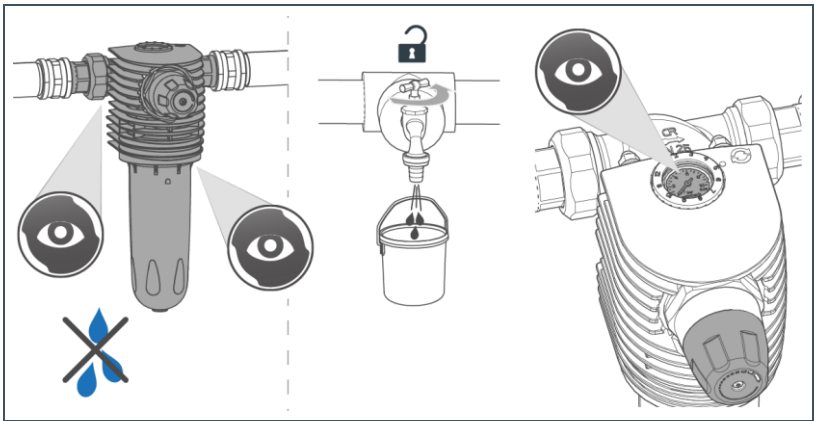

1. Check the installation for leaks and function.
 2. Read the static pressure (zero flow) of BOXER KDX.
 3. Fully open a water withdrawal point (generate max. flow) and read the flow pressure.
- ▶ Replace the filter element in case of increasing contamination of the filter element and/or decreasing water pressure in the pipe network.

8.4 Maintenance

Regular work is required in order to ensure the proper functioning of the product in the long term. DIN EN 806-5 recommends regular maintenance to ensure trouble-free and hygienic operation of the product.



WARNING

Irregularly replaced filter element and contaminated support mesh

- Health risk due to contamination of the drinking water
- ▶ Comply with the intervals for inspection and replacement of the filter element (according to DIN EN 806-5 every 6 months at the latest).
- ▶ Dispose of the used filter element.

8.4.1 Semi-annual maintenance

Proceed as follows to carry out the semi-annual maintenance:

8.4.1.1 Preparing the replacement of the filter element

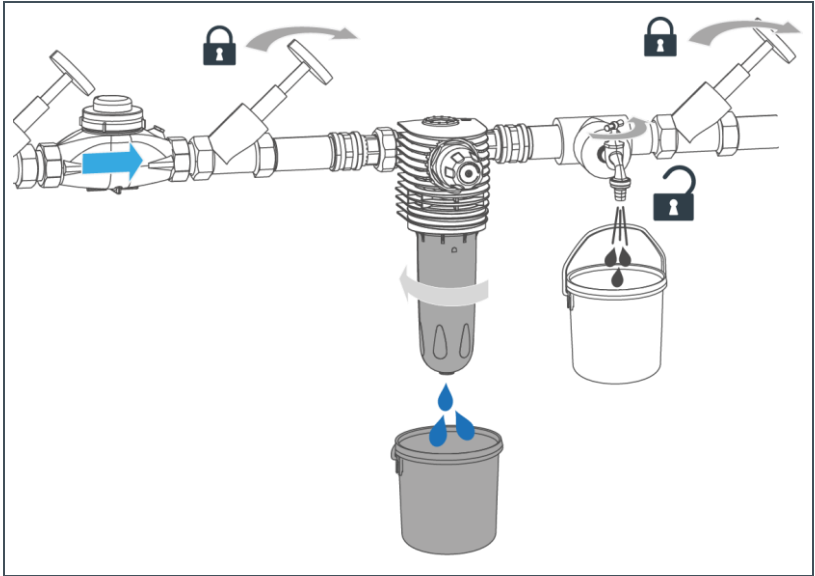

1. Place a bucket (min. 10 l) under the filter.
2. Close the shut-off valves on the inlet and on the outlet.
3. Open a water withdrawal point and wait for a few seconds.
 - » The pressure in the filter and the pipe network is being relieved.

8.4.1.2 Replacing the filter element hygienically

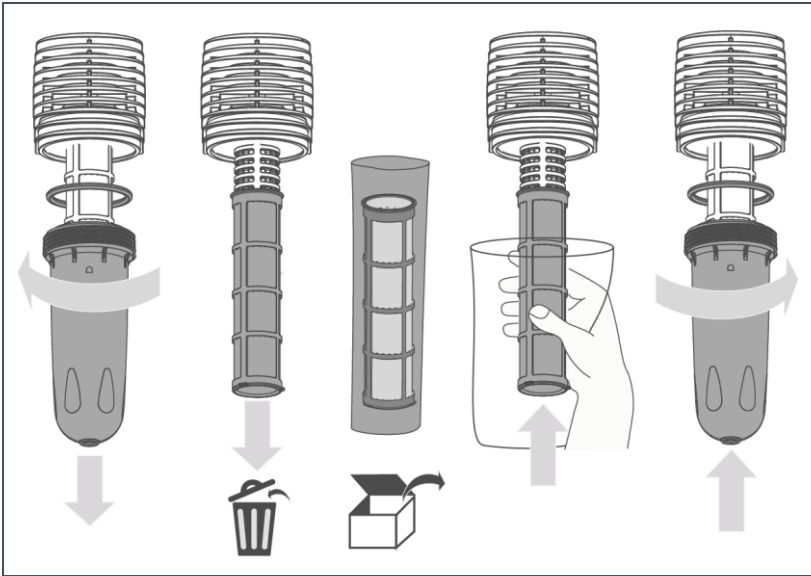

1. Unscrew the filter cylinder by hand. Use a strap wrench, if needed.
2. Pull off the O-ring with the filter cylinder.
3. Pull off the used filter element from the support mesh.
4. Dispose of the used filter element (refer to chapter 11.2).



For hygienic reasons, do not touch the new filter element and the support mesh with bare hands.

- Use hygienic gloves.

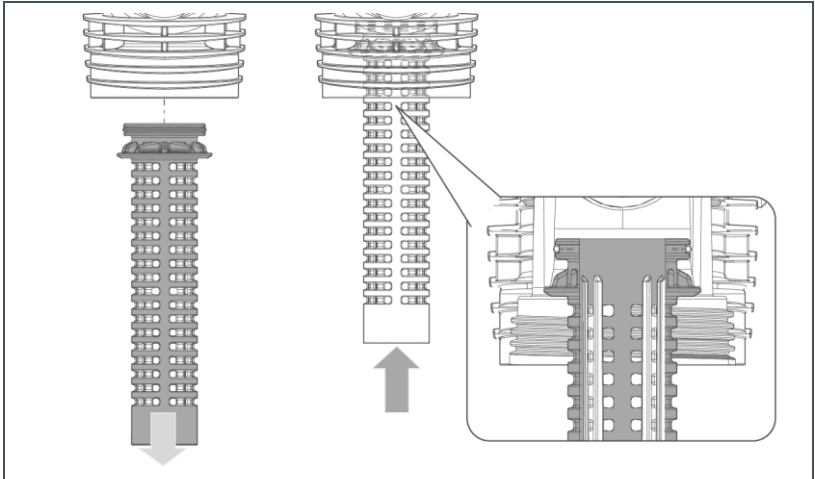

5. Clean the support mesh in case of major impurities.
 - a Pull the support mesh off downwards.
 - b Rinse the support mesh with water.
 - c Insert the support mesh into the filter head as far as it will go.
6. Slide the new, filter element in its foil packaging over the support mesh.
7. Check the sealing surfaces and the O-ring of the filter cylinder for cleanliness.
8. Replace the O-ring of the filter cylinder, if needed.

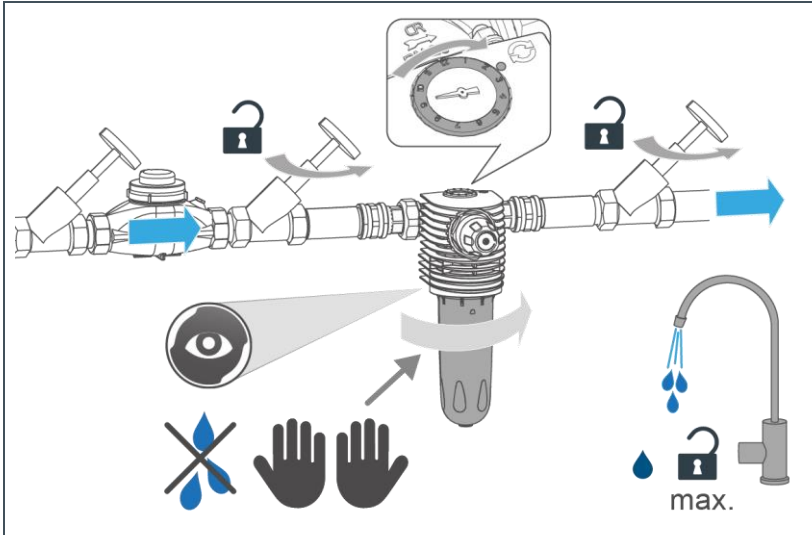

9. Clean the filter cylinder with clear water.
10. Screw in the filter cylinder by hand as far as it will go – do not use a strap wrench.
11. Put the filter into operation (refer to chapter 6.1).
12. Set the date for the next maintenance (refer to chapter 6.2).

8.4.2 Annual maintenance as needed

If a leak or a malfunction is detected, carry out a wear and tear test in addition to the semi-annual maintenance.

1. Check the O-rings and flat seals for wear and tear.
2. Check for the tight fit of the filter in the pipe.
3. Check the pressure reducer cartridge for a tight fit, (BOXER KDX). Retighten the screw, if needed (refer to chapter 6.3).
4. Replace worn components.

8.5 Consumables

NOTE

The filter element must not be cleaned.

- Risk of hygienic contamination.
- ▶ Dispose of the used filter element.

Illustration	Product	Quantity	Order no.
	100 µm filter element	2 pieces	101 272

8.6 Spare parts

For an overview of the spare parts, refer to our spare parts catalogue at www.gruenbeck.com. You can obtain the spare parts from your local Grünbeck representative.

8.7 Wearing parts



Wearing parts must be replaced by qualified specialists only.

Wearing parts are listed below:

- Seals (O-rings)
(Seal set for filter cylinder and support mesh, order no. 101625e)
- ▶ Have the seals replaced in the event of leaks, damage or distortions.

8.7.1 Recommended replacement interval

- 5 years for support mesh and seals
- 10 years for filter cylinder
- Have defective or worn components replaced.

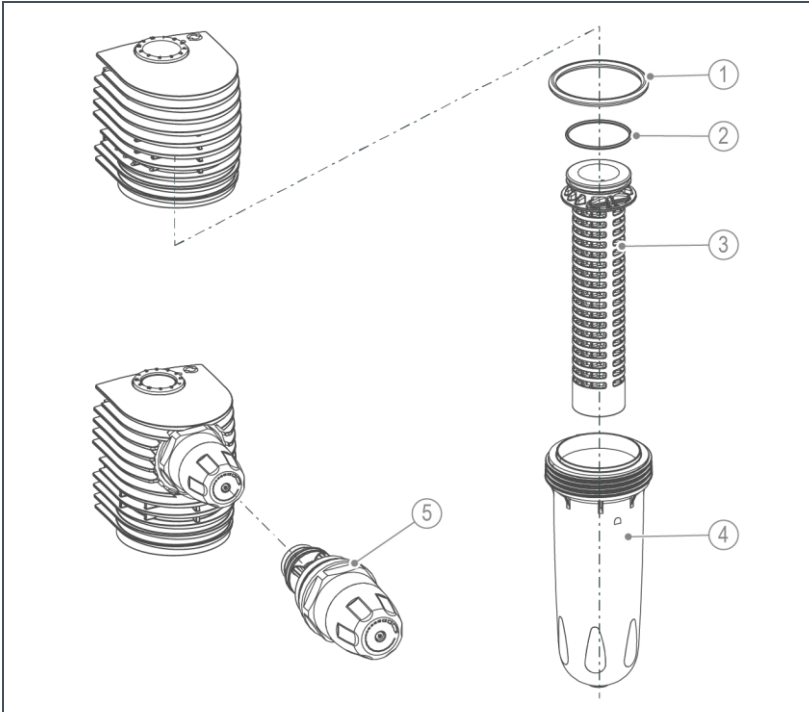

Designation
1 O-ring of filter cylinder
2 O-ring of support mesh
3 Support mesh

Designation
4 Filter cylinder
5 Pressure reducer cartridge

Tools required	Order no.
Strap wrench (to remove the filter cylinder)	105 805
Pipe socket wrench (for pressure reducer cartridge)	104 805

9 Troubleshooting



WARNING

Contaminated drinking water due to stagnation

- Infectious diseases
- ▶ Have malfunctions eliminated immediately.

9.1 Observations

Observation	Explanation	Remedy
Water pressure at the withdrawal point too low (pressure loss too high)	The shut-off valves are not fully open	▶ Fully open the shut-off valves
	The filter element is dirty	▶ Replace filter element
	The pressure reducer is not set correctly or is defective	▶ Have pressure reducer checked, adjusted or replaced by technical service
Taste of treated water negatively affected	Inappropriately long period of non-use (downtime)	<ul style="list-style-type: none"> ▶ Withdraw water for several minutes ▶ Replace filter element
Solids contained in the filtered water	Inappropriately high flow through the filter	▶ Check support mesh and filter element for damage or leaks
	Filter element or support mesh damaged or not installed correctly	<ul style="list-style-type: none"> ▶ Check the installation of the filter element and the support mesh ▶ Components: Replace filter element, support mesh and seals

Observation	Explanation	Remedy
Water loss in the system (leaks)	Faulty joint	<ul style="list-style-type: none">▶ Check O-rings and seals for deformations or wear and tear▶ Check filter head for damage▶ Have leaky components replaced by a qualified specialist



If a malfunction cannot be eliminated, the technical service personnel can take further measures.

- ▶ Contact technical service (refer to inner cover sheet for contact data).

10 Decommissioning

It is not necessary to put your product out of operation.



In case of longer absences, e.g. holidays, precautionary hygiene measures according to VDI 3810-2 and VDI 6023-2 must be taken in order to maintain drinking water hygiene after downtimes.

10.1 Temporary downtime

- ▶ Perform the activities below if the drinking water system has not been used for a longer period of time:

After a downtime of \leq 4 weeks

- ▶ Open a water withdrawal point and completely flush the filter and the pipes.

After a downtime of $>$ 4 weeks

1. Replace the filter element (refer to chapter 8.4.1).
2. Open a water withdrawal point and completely flush the filter and the pipes.

11 Dismantling and disposal

11.1 Dismantling



The work described herein represents an intervention into your drinking water system.

► Have this work carried out by qualified specialists only.

1. Close the shut-off valves upstream and downstream of the filter.
2. Open a water withdrawal point and wait for a few seconds.
 - » The pressure in the filter and the pipe network is being relieved.
3. Close the water withdrawal point.
4. Remove the filter cylinder and collect the escaping residual water in a container.
5. Remove the filter from the pipe.
6. Close the gap in your drinking water pipes, e.g. by using an adjusting piece.

11.2 Disposal

- ▶ Obey the applicable national regulations.

Packaging

NOTE

Danger to the environment due to incorrect disposal

- Packaging materials are valuable raw materials that can be reused in many cases.
- Incorrect disposal can cause hazards to the environment.
- ▶ Dispose of packaging materials in an environmentally sound manner.
- ▶ Obey the local disposal regulations.
- ▶ If necessary, commission a specialist company with the disposal.

Filter element

- ▶ Dispose of the used filter element with your household waste.

Product

- ▶ Make use of the collection points available to you for the disposal of your product.
- ▶ If your product contains batteries or rechargeable batteries, dispose of them separately from your product.



For more information on take-back and disposal, go to www.gruenbeck.com.

12 Technical specifications

12.1 BOXER KX

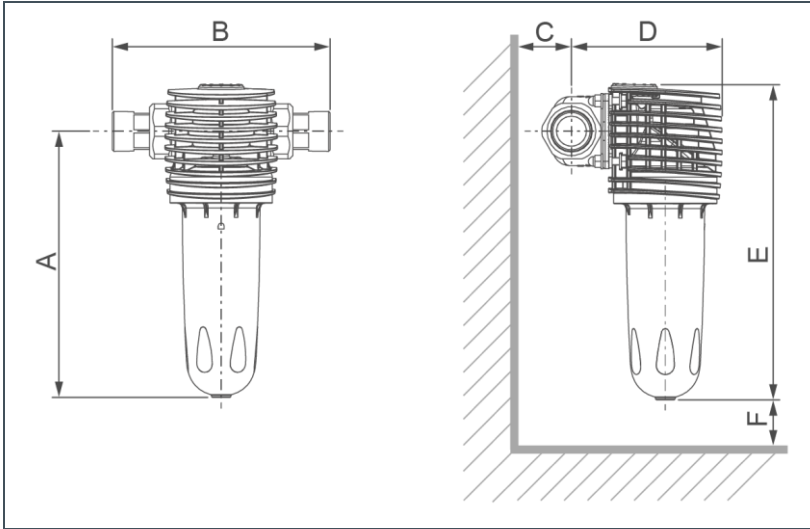

Dimensions and weights		BOXER KX			
Nominal connection diameter		DN 20	DN 25	DN 32	
Connection diameter		¾"	1"	1¼"	
A	Installation height up to centre of connection	mm	225		
B	Installation length with/without screw connection	mm	185/100	182/100	191/100
C	Distance to wall	mm	≥ 60		
D	Installation depth up to centre of connection	mm	115	120	125
E	Total height	mm	260		
F	Height required for replacement of filter element	mm	> 150		
Empty weight		kg	~ 1.7	~ 1.9	~ 2.2

Performance data		¾"	1"	1¼"
Nominal flow at Δp 0.2 (0.5) bar	m ³ /h	2.8 (4.5)	3.7 (6.0)	4.0 (6.3)
K _V value	m ³ /h	6.7	8.4	9.6
Pore size	µm	100		
Largest/smallest pore size	µm	120/80		
Operating pressure	bar	2 – 16		
Nominal pressure		PN 16		
General data		¾"	1"	1¼"
Water temperature	°C	5 – 30		
Ambient temperature	°C	5 – 40		
DVGW registration number		NW-9301DL0162		
ÜA registration number <i>The Office of the Vienna Provincial Government – City of Vienna</i>		R-15.2.3-21-17496		
Order no.		101 830	101 835	101 840

12.2 Pressure loss curves BOXER KX

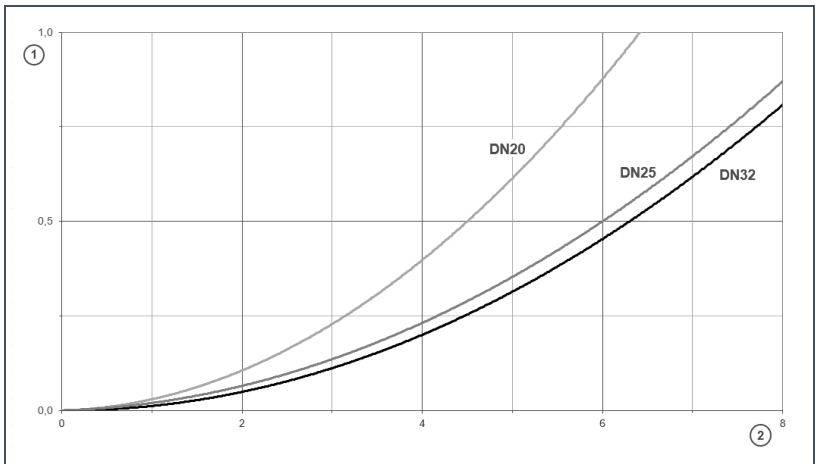

Designation

1 Pressure loss in bar

Designation

2 Flow rate in m³/h

12.3 BOXER KDX

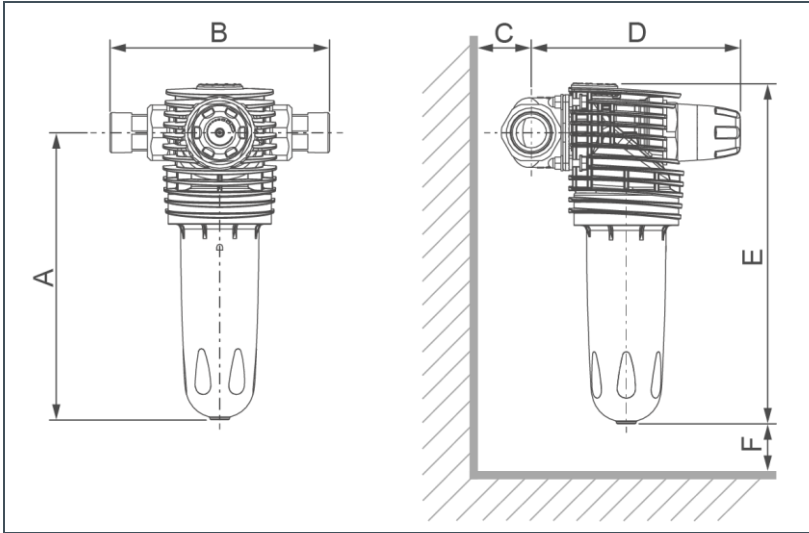

Dimensions and weights		BOXER KDX			
Nominal connection diameter		DN 20	DN 25	DN 32	
Connection diameter		¾"	1"	1¼"	
A	Installation height up to centre of connection	mm	240		
B	Installation length with/without screw connection	mm	185/100	182/100	191/100
C	Distance to wall	mm	≥ 60		
D	Installation depth up to centre of connection	mm	160	165	170
E	Total height	mm	280		
F	Height required for replacement of filter element	mm	> 150		
	Empty weight	kg	~ 2.0	~ 2.2	~ 2.5

Performance data		¾"	1"	1¼"
Flow rate as per DIN EN 1567	m³/h	2.3	3.6	5.8
Pore size	µm	100		
Largest/smallest pore size	µm	120/80		
Operating pressure	bar	2 – 16		
Nominal pressure		PN 16		
General data		¾"	1"	1¼"
Water temperature	°C	5 – 30		
Ambient temperature	°C	5 – 40		
DVGW registration number		NW-9311DL0167		
ÜA registration number <i>The Office of the Vienna Provincial Government – City of Vienna</i>		R-15.2.3-21-17496		
Order no.		101 815	101 820	101 825

13 Operation log



- ▶ Document the initial start-up/commissioning and all maintenance activities.

Fine filter BOXER _____

Serial no.: _____

13.1 Start-up/Commissioning log

Customer		
Name		
Address		
Installation/Accessories		
Floor drain present	<input type="checkbox"/> Yes	<input type="checkbox"/> No
Safety device	<input type="checkbox"/> Yes	<input type="checkbox"/> No
Operating values		
Water pressure at raw water inlet	bar	
Water pressure at water outlet	bar	
Residential water meter reading	m ³	
Start-up/Commissioning		
Company		
Service technician		
Work time certificate (no.)		
Date/signature		

Grünbeck AG
Josef-Grünbeck-Str. 1
89420 Hoechstädt/Germany

 +49 9074 41-0

 +49 9074 41-100

info@gruenbeck.com
www.gruenbeck.com



For more information go to
www.gruenbeck.com